

REVISION HISTORY			
REV.	DESCRIPTION	DATE	DRAWN BY
1	ORIGINAL PRINT	1/23/2026	P. YEUNG

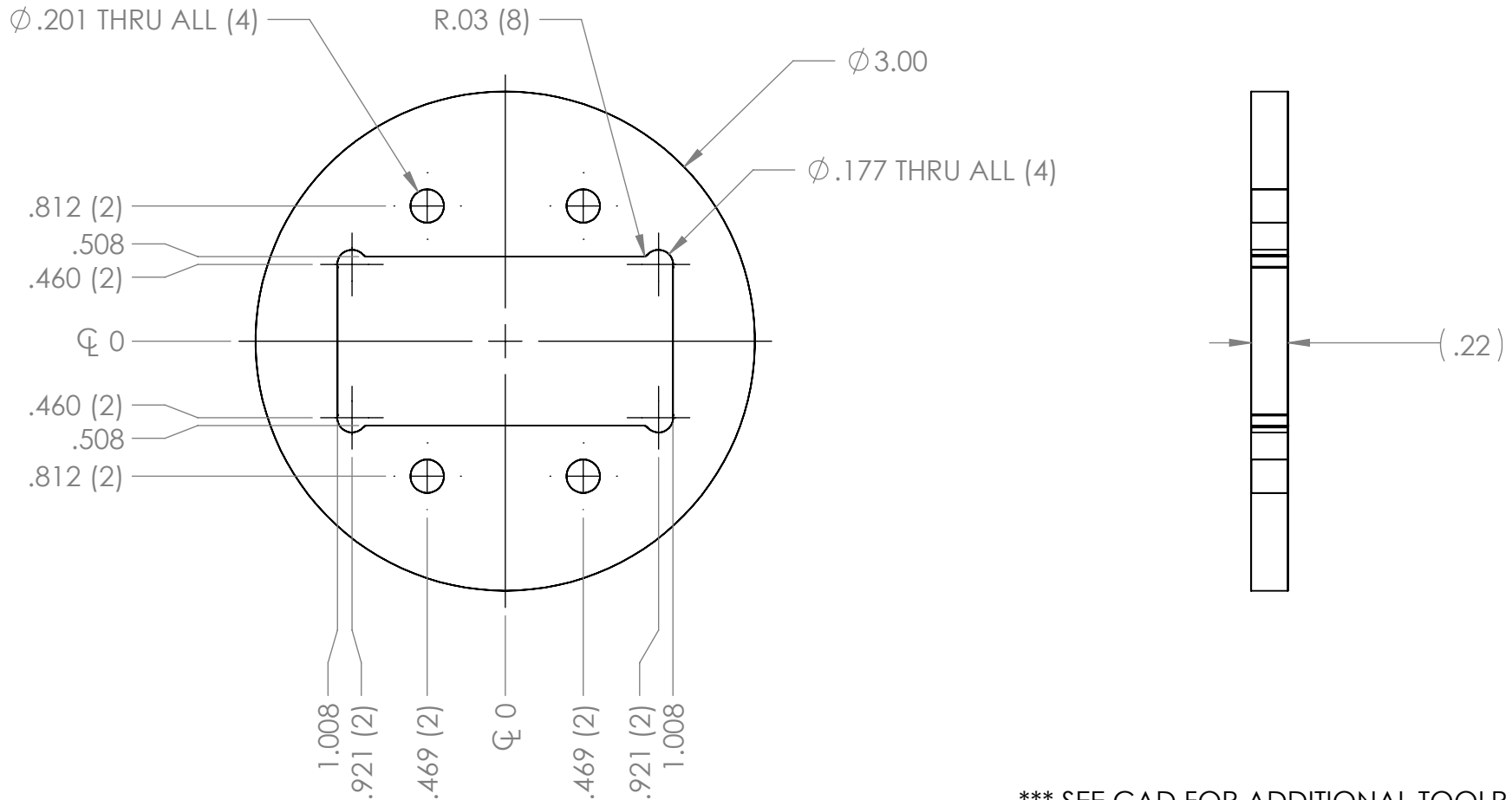

*** SEE CAD FOR ADDITIONAL TOOLPATH INFO***

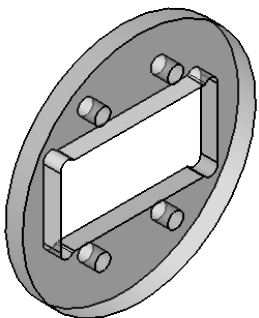

UNLESS OTHERWISE SPECIFIED:		COMMENTS:			
DIMENSIONS ARE IN INCHES		DUAL DIMENSIONS ARE IN MILLIMETERS.		TITLE:	
TOLERANCES:		BREAK ALL SHARP EDGES.		EVERYBOT 2026	
FRACTIONAL	$\pm 1/16$			SPROCKET ADAPTER	
ANGULAR: MACH	$\pm 1^\circ$			SIZE	DWG. NO.
ANGULAR: BEND	$\pm 5^\circ$			A	am-5804_adapter
ONE PLACE DECIMAL	± 0.1			REV	1
TWO PLACE DECIMAL	± 0.01			SCALE: 1:1	
THREE PLACE DECIMAL	± 0.005			SHEET 1 OF 1	
FOUR PLACE DECIMAL	± 0.0005				
MATERIAL	CLEAR PC rm-0031a	CHECKED	NAME NM	DATE 1/27/26	
FINISH	DEBURRED	ENG APPR.			
DO NOT SCALE DRAWING		MFG APPR.			
		Q.A.			